

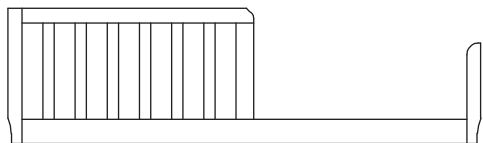

# Daybed Conversion Rail (M3099)- Assembly and Operation

## PARTS & HARDWARE



A. Guard Rail

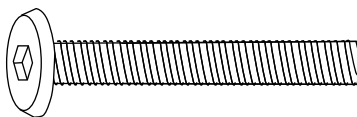

B. 1 3/4" Allen head bolt (4)

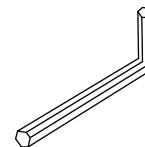

C. Allen wrench

### STEP 1.

Unscrew the bolts and remove the cross bar and front panel.

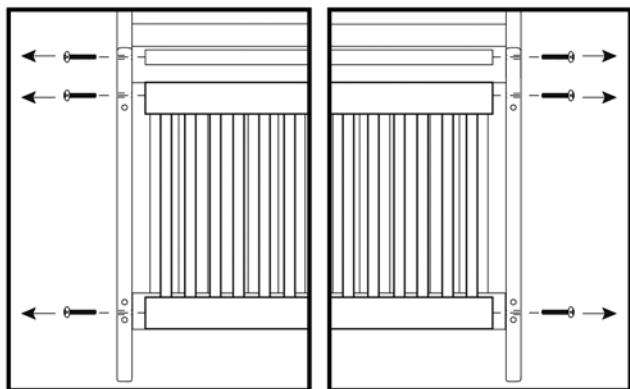

### STEP 2.

Move the spring frame to the lowest level.

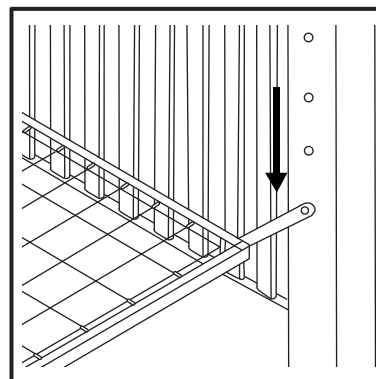

### STEP 3.

Attach the guard rail (A) to the side panel posts using four Allen head bolts (B).

**The guard rail can be installed with the high end facing either to the left or the right.**

Check to make sure that all of the bolts are fastened securely.

**Do not overtighten.**

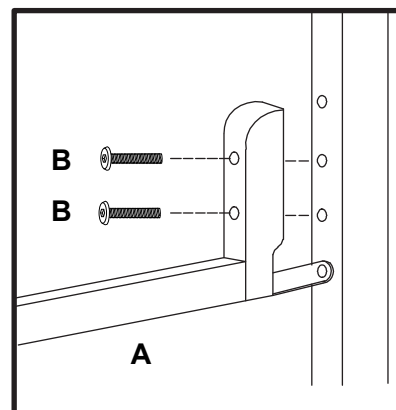
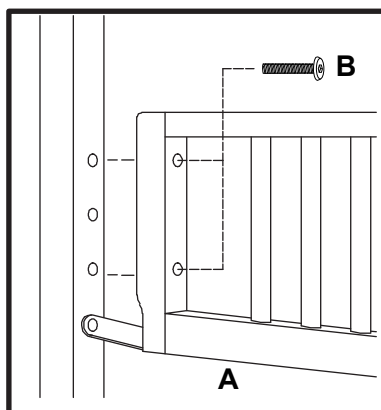

**The mattress intended for use on the bed shall be a full-size mattress having minimum dimensions of 51 5/8 " (1310 mm) in length, 27 1/4" (690 mm) in width and 4" (100 mm) in thickness and not exceeding 6" (152 mm).**

**The intended user's minimum age must be at least 15 months old and maximum weight must not exceed 50 lbs (22.7 kg).**

 **WARNING :**

**Failure to follow these warnings and the assembly instructions could result in serious injury or death from entrapment or strangulation.**

DO NOT place bed near windows where cords from blinds or drapes may strangle a child. DO NOT place items with a string, cord, or ribbon, around a child's neck, such as a hood strings or pacifier cords. DO NOT suspend strings over a toddler bed for any reason. If guard rails are used as the mattress containment means, guard rails provided must be used to avoid the formation of a gap between the mattress and the bed that could cause an entrapment.